



Inspiration

PROCESS

GOOD

H₂O

Saint-Etienne

Institute

OF

TECHNOLOGY



best day ever



IST INSTITUT
UNIVERSITAIRE DE
TECHNOLOGIE
SAINT-ETIENNE

Lined writing area with 20 horizontal blue lines.

Welcome TO THE SAINT-ETIENNE INSTITUTE OF TECHNOLOGY (IUT)

Saint-Etienne is situated in a beautiful region (Rhône-Alpes) of south eastern France, 50 km away from Lyon. You can be in Paris in less than 3 hours and in the famous Alps ski resorts of Grenoble in 2 hours. Students enjoy an active city life, with a multitude of different cultural activities and numerous sports facilities, as well as bars, clubs, restaurants and great shopping opportunities in the city centre. The surrounding area, with its valleys, forests and hills, is a treasure trove for nature lovers and offers unparalleled panoramic views and fantastic hiking opportunities. Saint-Etienne is well known for its International Design Exhibition in the autumn.

IUT Saint-Etienne is part of Jean Monnet University. There are around 2,200 students studying in a range of 7 departments (Accountancy, Management, Sales and Marketing, Applied Physics, Biological Engineering, Electrical Engineering and Industrial Computing and Mechanical Engineering) and we also offer 18 vocational degrees. A third of lessons are practical sessions in labs or workshops, in classes of less than 14 students.

IUT Saint-Etienne is a sociable, professional and dynamic place to further your studies. IUT Saint-Etienne is an eco-friendly campus: eco-pasture with sheep from Soay, 3 hives, shared gardens, waste sorting, carpooling ...

WE ENCOURAGE YOU TO JOIN US!

CONTENTS

About Saint-Etienne	P.4
About Université Jean Monnet and Saint-Etienne IUT	P.7
About academic programs	P.12
French center language	P.26
Accommodation	P.27
Facilities	P.28
Admission	P.30

4 about Saint-Etienne

Saint-Etienne is France's **14th largest city**.
 Saint-Etienne Métropole is the 2nd largest metropolitan area in the Rhône-Alpes region and the 6th largest in France:

- 43 cities
- 400 000 inhabitants



GETTING TO SAINT-ETIENNE

- Direct T.G.V. from Paris (2h50)
- A47 motorway (Lyon/Saint-Etienne in 40 minutes)
- Shuttle service between Lyons' St Exupéry international Airport and downtown Saint-Etienne (50 minutes)
- Heliport (10 minutes from downtown Saint-Etienne)

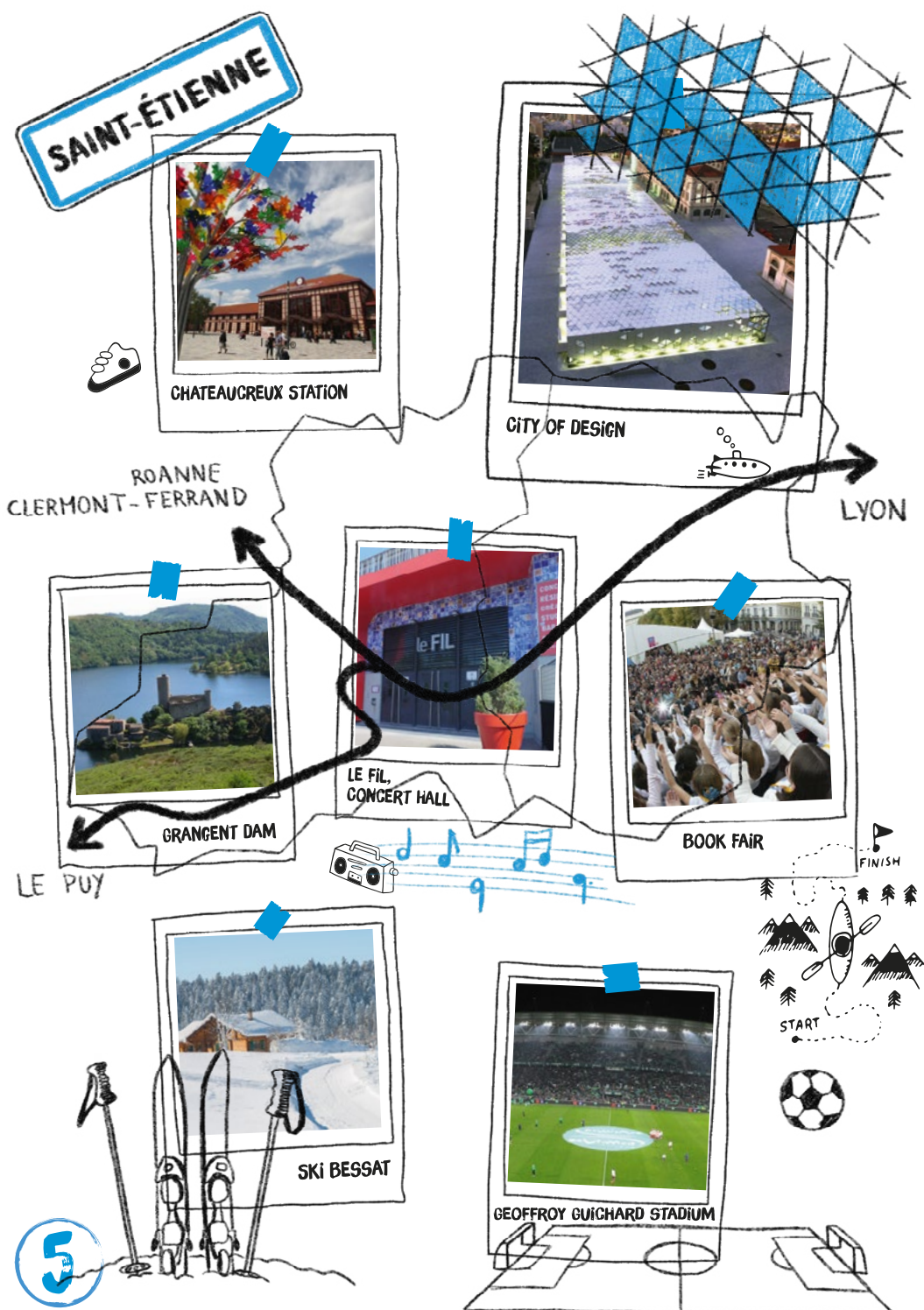

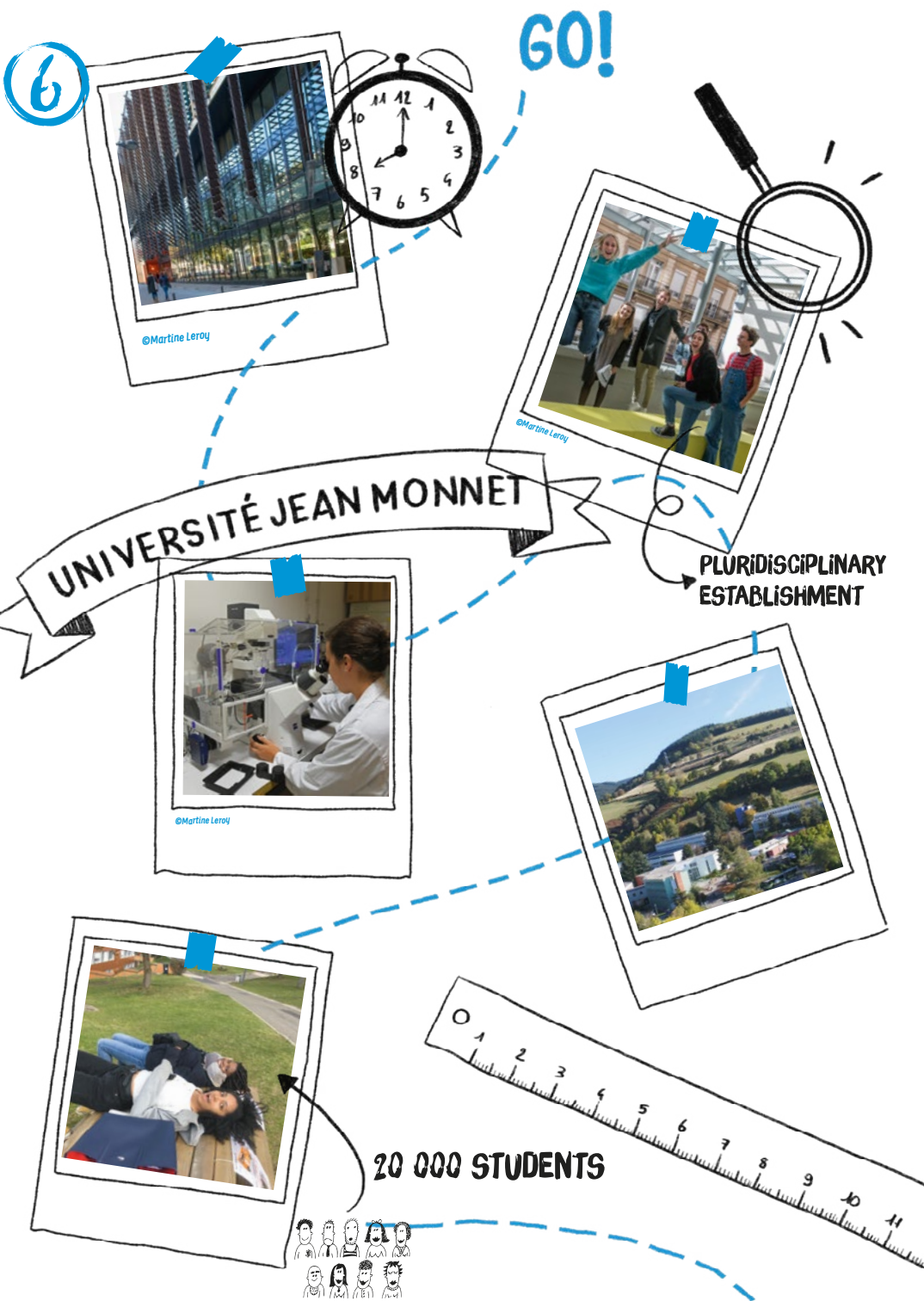

about université jean monnet

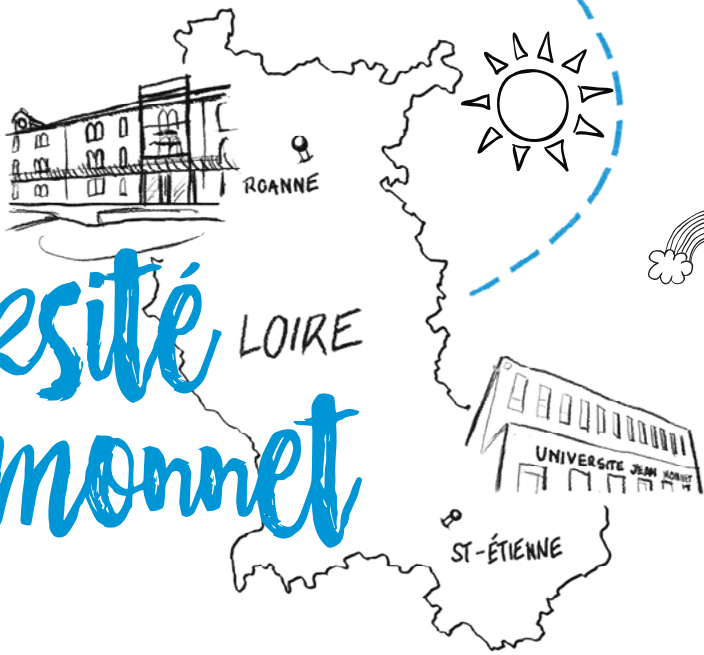

Université Jean Monnet is located in the towns of Saint-Etienne and Roanne, in the Rhône-Alpes Region. Its population has a tradition of hospitality only to be found in towns of this scale. You will enjoy a vast range of cultural and sports activities such as leisure parks with tracks for mountain biking, hiking, skiing as well as a nautical base for sailing which is just 15 minutes away from the university.

Université Jean Monnet is a genuinely **pluridisciplinary establishment** truly in sync with contemporary society and offering a hospitable working environment with quality study and research programmes as well as a rich network of international relations.

SOME FIGURES

- 20,000 students
- 1,500 members of staff
- 6 main academic fields
- 10 Faculties or Institutes
- 33 research units
- Université Jean Monnet: a pluridisciplinary establishment offering
- Research programmes
- Rich network of international relations

8 about the saint-étienne institute of technology



AN IDEAL SETTING

Close to the city centre by bus, with easy access to Saint-Etienne's major train station (20mn ride), the Saint-Etienne Institute of Technology offers you a privileged working environment in a city with a very wide range of good value accommodation for its size.

Within walking distance of the scientific campus of La Métare and its facilities (library, restaurant, cafeteria), the Institute of Technology also has its own:

- cafeteria
- healthcare services
- free access computer rooms open all day

We also have a total of 2,200 students enrolled in:

- 7 two-year undergraduate vocational courses
- 18 vocational bachelor's degrees
- 6 university diplomas
- Courses taught in French and some in English

OUR TWO-YEAR UNDERGRADUATE VOCATIONAL COURSES

We offer a good compromise between further education and the working world.

Technical courses with the right balance between general and vocational subjects:

- Workshops and seminars in small groups (12 in workshops, 24 in seminars)
- Work placements (10 weeks minimum) helping develop the autonomy and integration skills students need to join a company.

Our seven departments, three of which cover the Tertiary Sector, offer a wide choice of courses Completed by a wide choice of professional degrees:

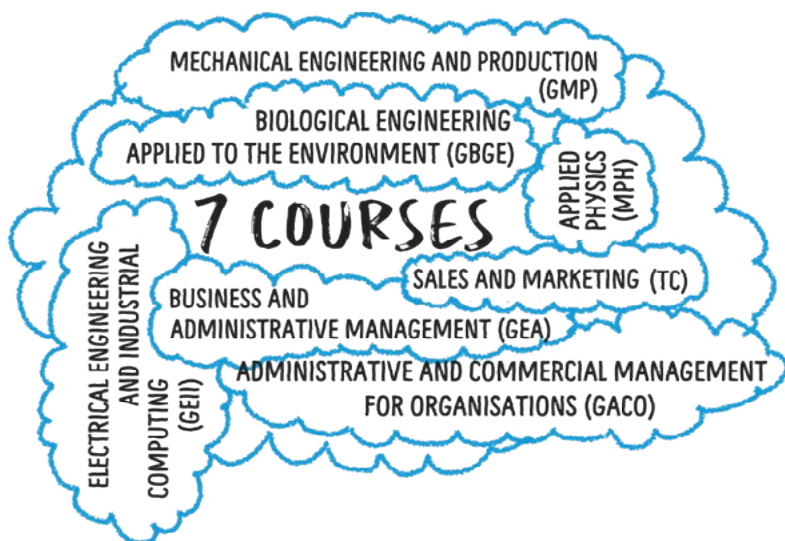

OUR VOCATIONAL DEGREES

The Institute of Technology has **18** vocational degrees, thirteen of which are on a sandwich course basis (apprenticeship, work contract) in a range of majors (either industry or service related)

Passing a vocational degree enables you to get a double competence or a major acknowledged by professionals.



Courses taught in English:
<http://www.iut.univ-st-etienne.fr/en/training-offer.html>

The international relations department 10

"THE INTERNATIONAL RELATIONS DEPARTMENT IS FIRST A DYNAMIC TEAM AND HAS ONE INTERNATIONAL COORDINATOR IN EACH DEPARTMENT!"

We also make welcoming exchange students one of its most important areas of development.



Upon their arrival in Saint-Etienne, with the welcome day on campus, a help in their administrative or housing search procedures, and active assistance to facilitate their integration into cultural and associative campus, the international relations department works with exchange students and develops a range of tools to improve their daily lives during their mobility.



COURSE CHARACTERISTICS

- a foundation course during the first two semesters, then an option choice for semesters 3 and 4
- 1620 hours = 60 weeks over 2 years
- 30 contact hours a week
- 11-week in-company training and research project
- tutored projects
- Personal and Professional Project
- **Language of studies:** French and some in English. Introduction to the French language & culture: compulsory course (for all foreign students)
- **Duration:** 2 years (full-time)
- **Academic volume:** 120 ECTS

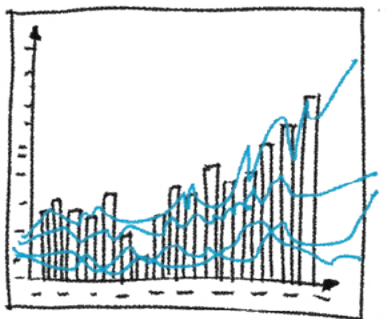

KEY SUBJECTS

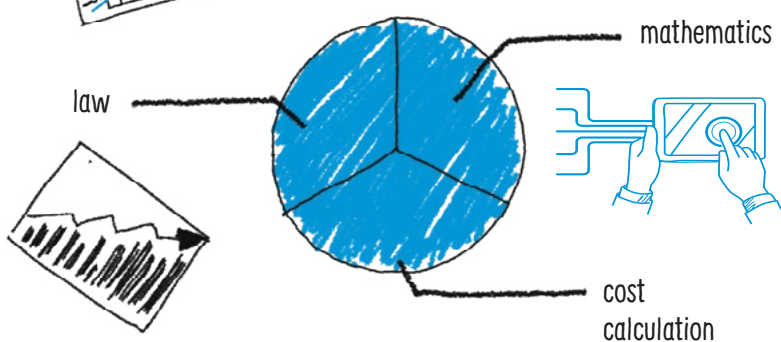

COURSE GOALS

After having completed their studies, graduates are able to:

- Participate in company development
- Be functional in companies from the private and public sectors as well as in professional bodies and associations
- Master quantitative and qualitative methods
- Make an immediate and effective contribution to applying management techniques in a business environment



LABELS

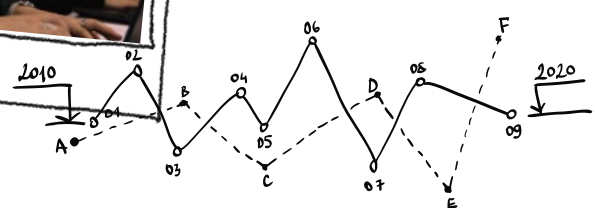
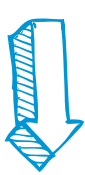
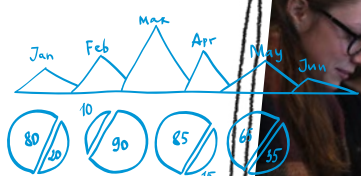

CAREER PROSPECTS

- Main areas: Accounting and financial departments, banks and insurance companies, industrial or commercial firms, private sector
- Scope of activities: General accounting, business tax system, social law, fiscal management, business organization, auditing.

ADMINISTRATIVE AND COMMERCIAL MANAGEMENT FOR ORGANISATIONS (GACO)

COURSE CHARACTERISTICS

- 48 weeks over 4 terms/ 2 years
- 1 or 2 months in-company internship (May-June) – Possible placements abroad
- Tutored projects and Business games
- A relevant degree in response to changing economic, commercial and technological environment combined with a real practical focus.
- Strong links with companies and local socio-economic environment
- Lab work and seminars in small groups – 14 and 28 students (more than 70% of the teaching)
- Staff from business and academic background (professionals from local companies / teachers and researchers)
- Special emphasis on IT
- An international focus: TOEIC preparation courses, Language labs and multimedia facilities.
- A postgraduate International diploma open to DUT holders
- **Language of studies:** French and English – A minimum of B2 level in English is highly recommended to obtain the credits.

Introduction to the French language & culture: compulsory course (for all foreign students)

- **Duration:** 2 years (full-time)
- **Academic volume:** 120 ECTS

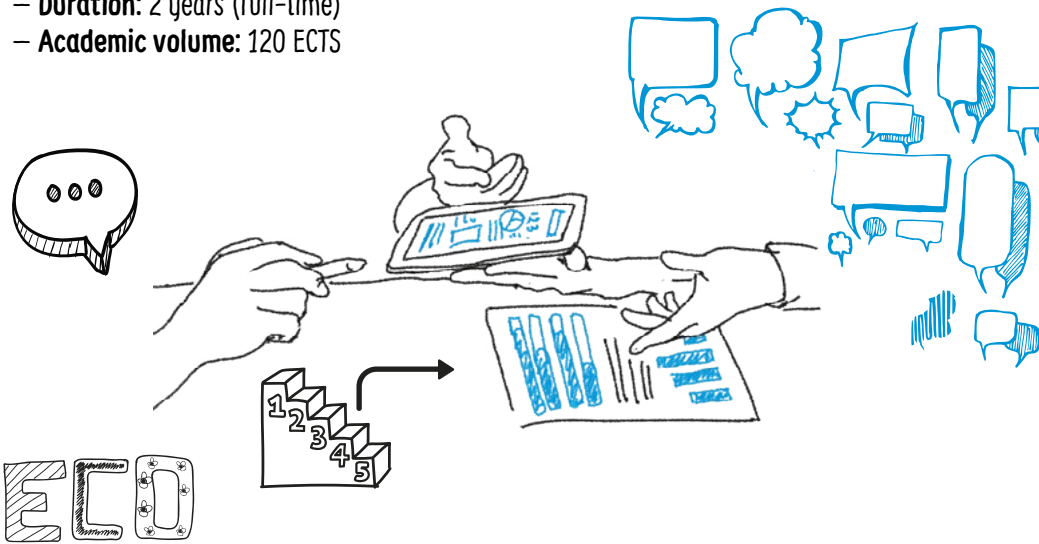

KEY SUBJECTS

- Versatility
- Project management
- Entrepreneurship
- Digital communication
- International

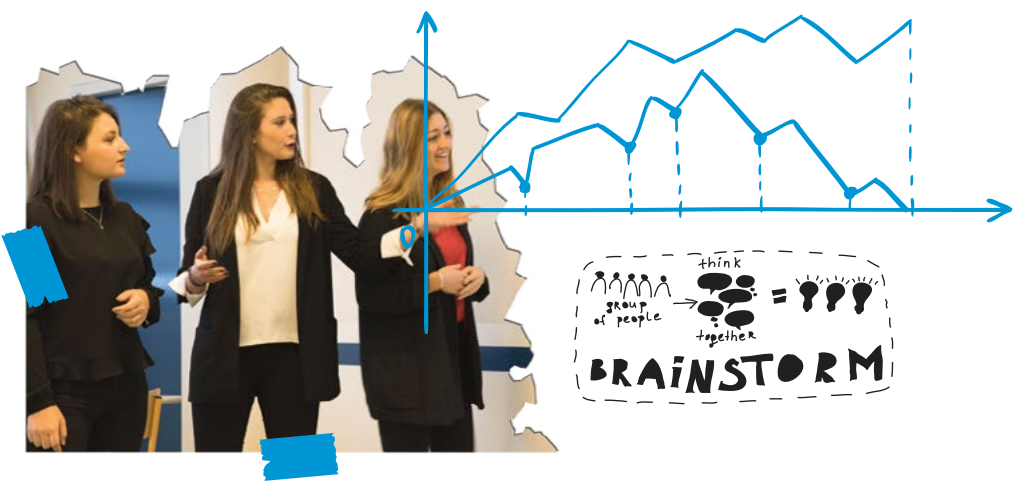

COURSE GOALS

- To train our students to be dynamic, employable and versatile professionals.
- To prepare Business Managers with Marketing, Management, ICT, Accounting and language skills.
- Autumn semester Economics, Accounting, Marketing, Negotiation and sales, Logistics, English for business, Business games, Tutored project
- Spring semester Economics, Accounting, Mix Marketing, ICT, Website design e marketing, English for business, Business games



CAREER PROSPECTS

Main Areas: Marketing, Human Resources, Accounting, Administration, Communication

COURSE CHARACTERISTICS

The right balance between vocational and general training

- 1600 hours of lessons over 4 semesters (120 ECTS credits)
- 2 foreign languages mandatory
- Work placements: 3 weeks for 1st Year, 10 weeks for 2nd Years
- Tutored projects for 1st and 2nd Years
- Cross disciplinary skills and Personal Professional Plan
- Tutored Project: a real market research project leading to a commissioned report for a company and followed by an oral presentation.
- Work Placements: gain the experience in all sectors of the sales and marketing process in a real company. Possibility of carrying out the placement abroad.
- **Language of studies:** French and some in English. Introduction to the French language & culture: compulsory course (for all foreign students)
- **Duration:** 2 years (full-time)
- **Academic volume:** 120 ECTS

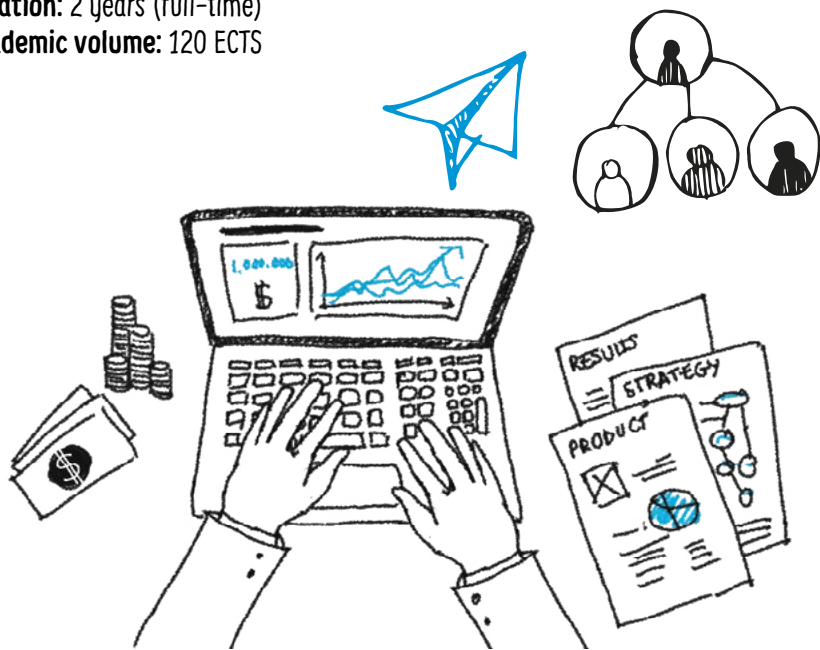

KEY SUBJECTS

- Marketing and Strategy: designing a marketing plan and implementing a strategy.
- Market research: becoming a junior consultant, understanding the market and helping companies in their decision making process.
- Digital and Corporate Communication: building a communication plan and mastering the digital tools.
- Sales and Negotiation: convincing the customers and managing the workforce.
- Entrepreneurship and Innovation: developing innovative ideas from the first spark to the conception.



COURSE GOALS

- To train students to take on versatile, autonomous, open-ended commercial jobs
- To support students with a real profession-oriented university course
- To prepare them to join professions or continue their studies further.

CAREER PROSPECTS

Main Areas: Marketing, Communication, Sales, Manager...

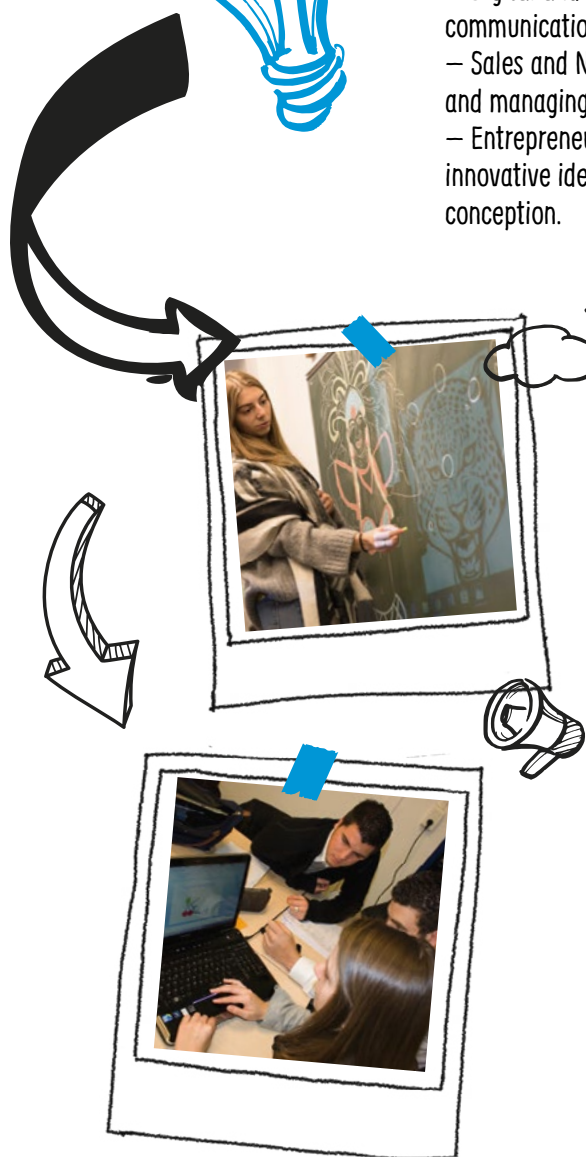

APPLIED PHYSICS (MP)

SPECIALIZED IN INSTRUMENTATION
OR PHYSICO-CHEMICAL CONTROLS AND MATERIALS

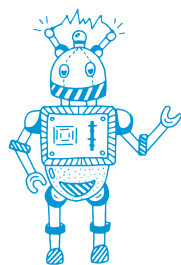

COURSE CHARACTERISTICS

- A general and professional course based on experimental practice
- Wide range of technical and scientific fields: physics, chemistry, materials, practical applications, mathematics, industrial computing, metrology etc.
- Communication skills: French and English courses, management and internal and external business relationship management.
- Professional project and tutored project
- Minimum 10-week internship in a company and research project
- **Language of studies:** French and some in English.
- **Duration:** 2 years (full-time)
- **Academic volume:** 120 ECTS

KEY SUBJECTS

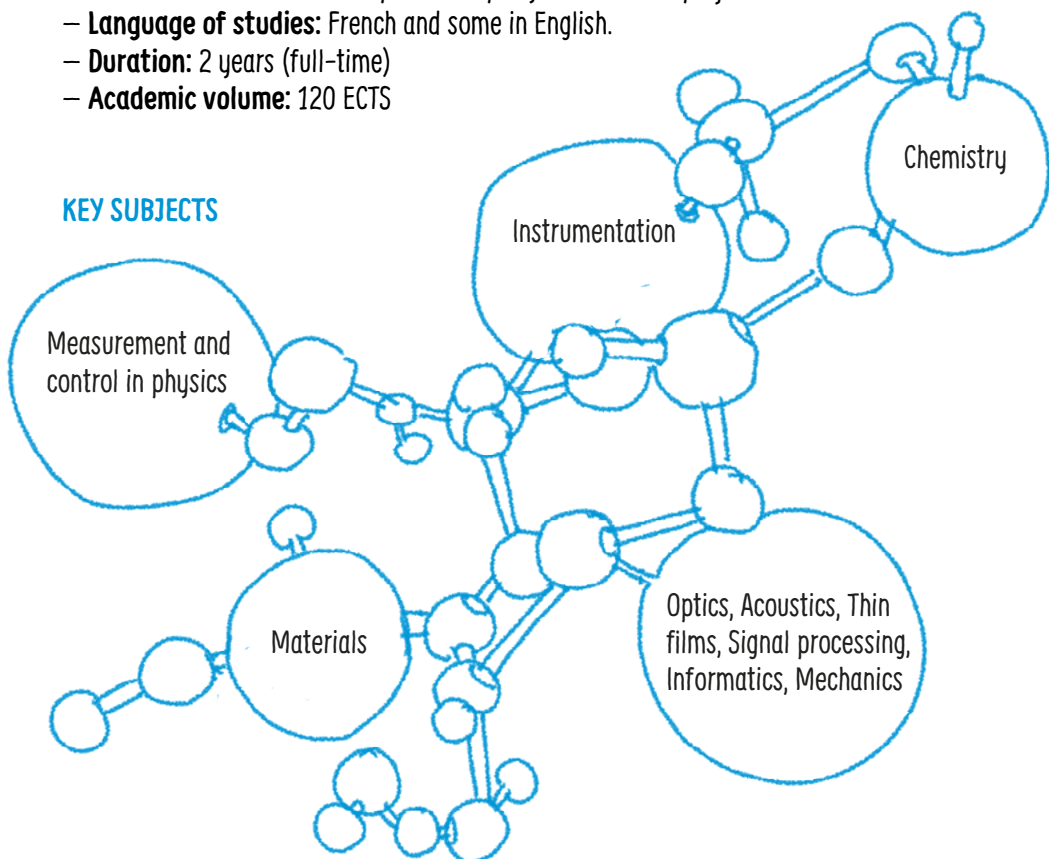

ASSESSMENT

- Wide range of technical and scientific fields: physics, chemistry, materials, practical applications, mathematics, industrial computing, metrology etc.
- Communication skills: French and English courses, management and internal and external business relationship management.

COURSE GOALS

- In the fields of the key subjects, graduated students will be able to:
- Play an inter-active part in the setting-up of this policy
 - Meet technical, economic, quality and safety requirements needed in a competitive economy
 - Have the capacity to deal with situations demanding both autonomy and responsibility
 - Participate in company development

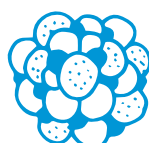

CAREER PROSPECTS

The technicians having graduated from their Physical Measures DUT find jobs in a laboratory, in production or in a research department in the following fields:

- research and development
- Measurement, control, tests and trials
- metrology
- quality

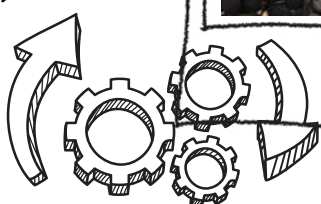

- production and industrialization
- maintenance
- sale of scientific instruments (technical salesman)

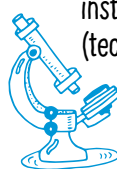

In the field of Energy, environment, car industry, aeronautics, chemistry, bio and medical industries...

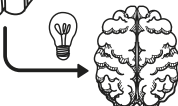
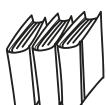

BIOLOGICAL ENGINEERING APPLIED TO THE ENVIRONMENT (GBGE)



COURSE CHARACTERISTICS

- Hours = 1800 hrs over 2 years
- Minimum 10-week in-company training and research project
- 120 H tutored projects
- A Career oriented diploma: industry oriented teaching: close university/industry links: staff from industrial and University backgrounds.
- Main language (second language possible): English, German, Spanish, Italian
- Preparation for the TOEIC
- Language assistant classes for extra English, German and Spanish
- 4 language labs + 3 specific multimedia classrooms equipped for language learning
- **Language of studies:** French and some in English. Introduction to the French language & culture: compulsory course (for all foreign students)
- **Duration:** 2 years (full-time)
- **Academic volume:** 120 ECTS

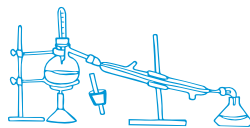

sanitary control,
risk and impact studies

knowledge of the ecosystems (ecology,
hydrogeology, pedology, climate)

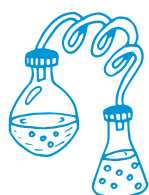

environmental
management and law

KEY
SUBJECTS

analysis and treatment
of pollutions (chemical,
physical, biological) in
soil, water and air.

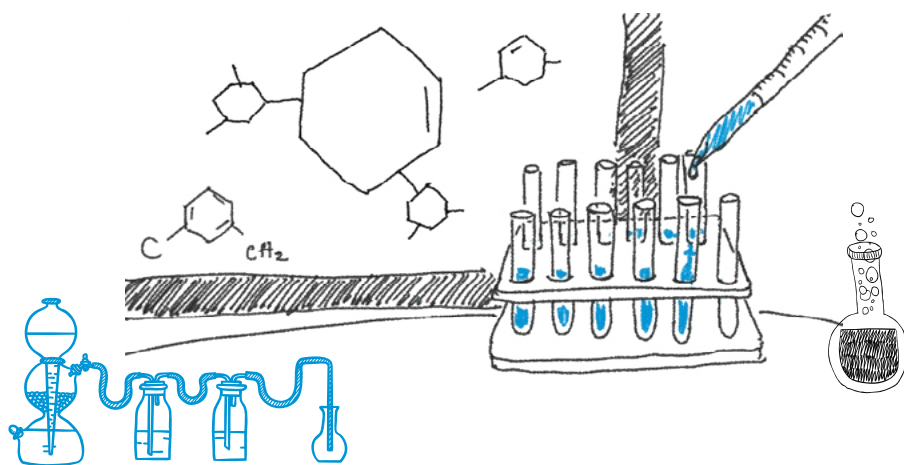

COURSE GOALS

After having completed their studies, graduates are able to:

- Take action in all areas related to the environment (water, air, soil...),
- Master analytical environmental techniques in chemistry, ecotoxicology and microbiology fit to work as a team throughout a project,
- demonstrate versatility (field, laboratory, studies...),
- deal with situations demanding both autonomy and responsibility.

CAREER PROSPECTS

Main areas: chemistry, microbiology, ecotoxicology, water treatment, waste treatment
Scope of activities: Biotechnologies, civil engineering, field work, town and country planning, safety, research and engineering offices (departments)

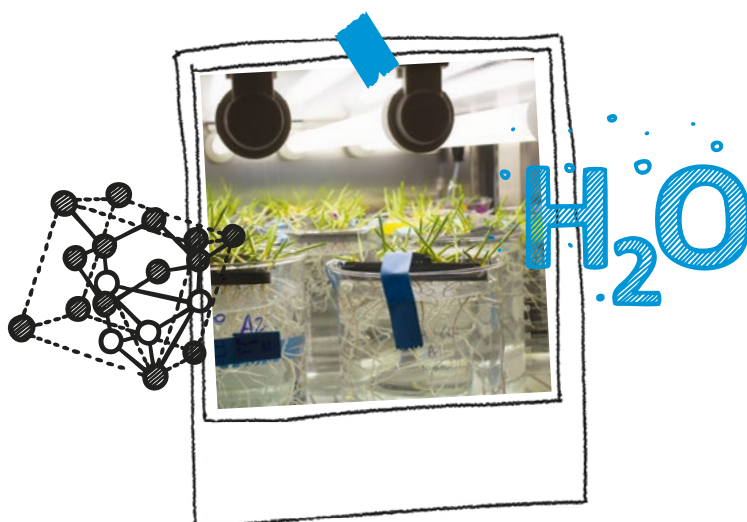

ELECTRICAL ENGINEERING AND INDUSTRIAL COMPUTING (GEII)

COURSE CHARACTERISTICS

- Hours = 1800 hours over 2 years
- minimum 10-week internship and research project
- 120 H tutored project(s)
 - A career oriented diploma: an industrial oriented pedagogy: strong links between education and industry: staff composed of both academics and professionals
 - Stress put on foreign languages: compulsory foreign language: English, optional foreign languages: German, Spanish, Italian, Russian, Chinese, preparation to the TOEIC test, a number of classes with a language Assistant, 4 language labs + 3 specific multimedia classrooms equipped for language learning
 - **Language of studies:** French and some in English. Introduction to the French language & culture: compulsory course (for all foreign students)
 - **Duration:** 2 years (full-time)
 - **Academic volume:** 120 ECTS
 - Opportunities to attend semester 4 in Russia or Quebec.

KEY SUBJECTS

- Electrotechnics and power electronics
- Analog and digital electronics
- Automation
- Control engineering
- Computer science
- Embedded systems
- Networks
- Mathematics
- Physics
- English

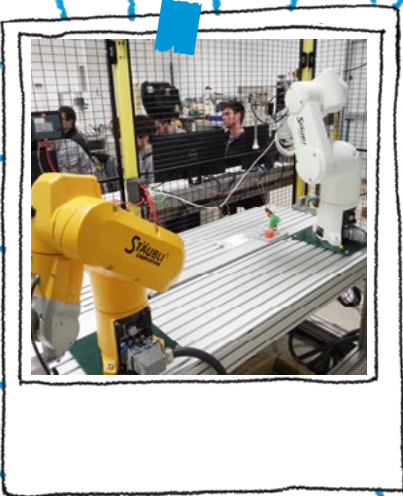
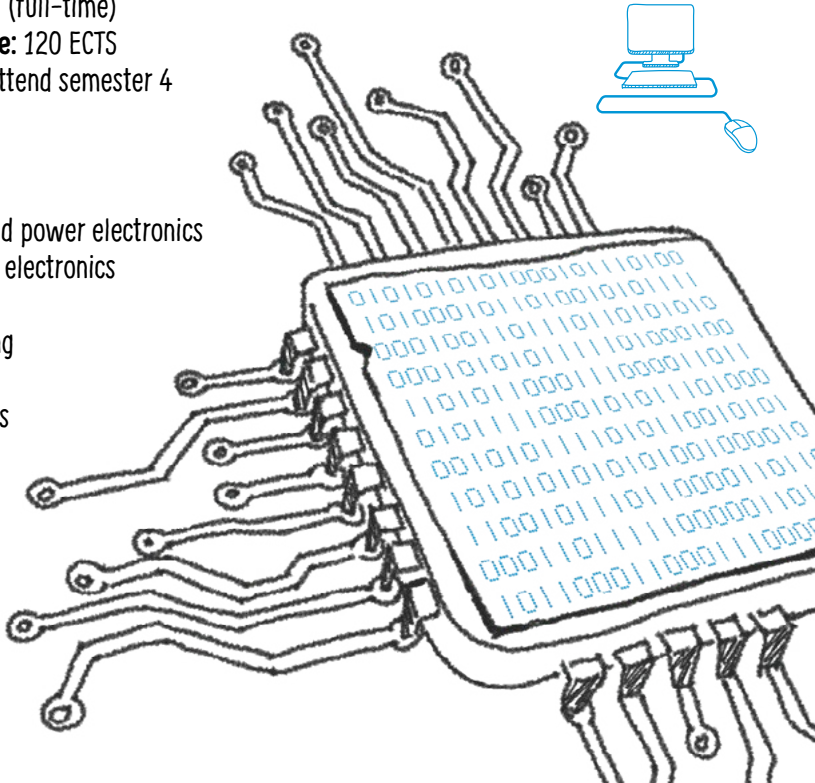

COURSE GOALS

- After completing their studies, graduates are able to:
- Participate in the development of a company
 - Play an inter-active part in the setting-up of company policy
 - Meet technical, economical, quality and safety requirements needed in a competing economy
 - Have the ability to deal with situations requiring both autonomy and responsibility

CAREER PROSPECTS

Main areas: small or large industrial companies, any firm in which electronics, electrotechnics and automation are used.
 Scope of activities: Microelectronics, Electronics, Automated Systems, Programmable Automation, Research, Maintenance, Telecommunications, Electrical Equipment and Fittings, Instrumentation, Production and Transport of energy, Space and Aeronautics, Health, Farm Product Industry, Transport and car industries, etc.



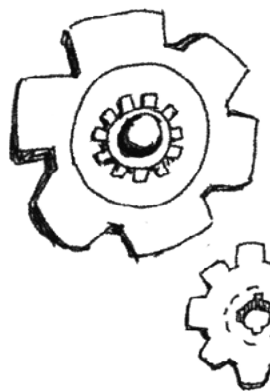

COURSE CHARACTERISTICS

- 4 semesters (September 1st to mid-January/January to June)
- Average number of contact hours 30 hours/a week (1,800 contact hours)
- 10-week of industrial work placement
- Team projects to carry out within tutored projects
- Tutorials: 26 students per group
- Lab work: 13 students per group
- Continuous assessment & 2-hour written assessment each week
- A career oriented diploma: industry oriented teaching: close university/industry links: Staff including professionals and professors.
- Well-equipped workshop (a water-jet cutting machine, a 5 axis drilling machine, lathes, a 3D printer, a robotic arm, a measuring column..); 4 language labs + 3 specific multimedia classrooms equipped for language learning.
- Opportunities to attend semester 4 in Russia or Quebec.
 - **Language of studies:** French
 - **Duration:** 2 years (full-time)
 - **Academic volume:** 120 ECTS

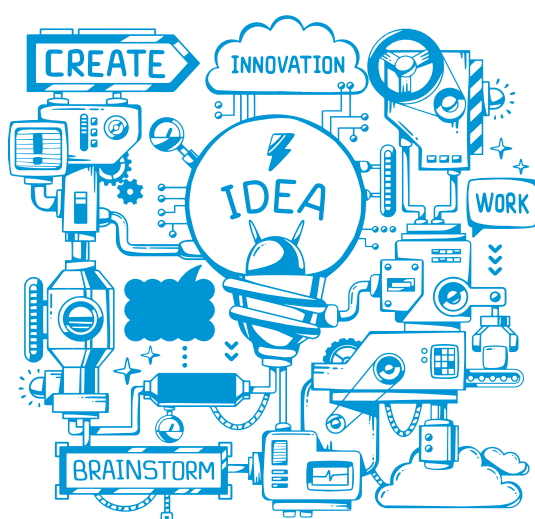

KEY SUBJECTS

- Industrialisation
- Production
- Control
- Mechanics
- Material science
- Management



COURSE GOALS

After having completed their studies, graduates are able to:

- Participate in the company development
- Play an interactive role thanks to their soft and technical skills
- Meet technical, economical, quality and safety requirements needed in a competing economy
- Have the capacity to deal with situations demanding both autonomy and responsibility

CAREER PROSPECTS

Main areas: any mechanical engineering oriented firm – electrical engineering firms and chemical industry – food industry



Scope of activities: research and design, tooling and facilities planning department, quality and control methods, production planning and management departments, manufacturing and production, commercial engineer



French language counter

26



The **CILEC** (international Centre for Language and Civilization) has more than 30 years experience in teaching French. It hosts about 300 students of many different nationalities.



The CILEC is welcoming you all year round, from September to August included, both during the academic year and summer. We offer extensive or intensive classes, from 2 hours to 20 hours a week, according to your availability. Upon your arrival, you will benefit from an assessment of your French writing and speaking skills in order to be part of the group that suits you best, according to the Common European Framework of Reference for Languages, from A1 to C2.

<https://cilec.univ-st-etienne.fr/en/>

Introduction to the French language & culture: compulsory course (for all foreign students).

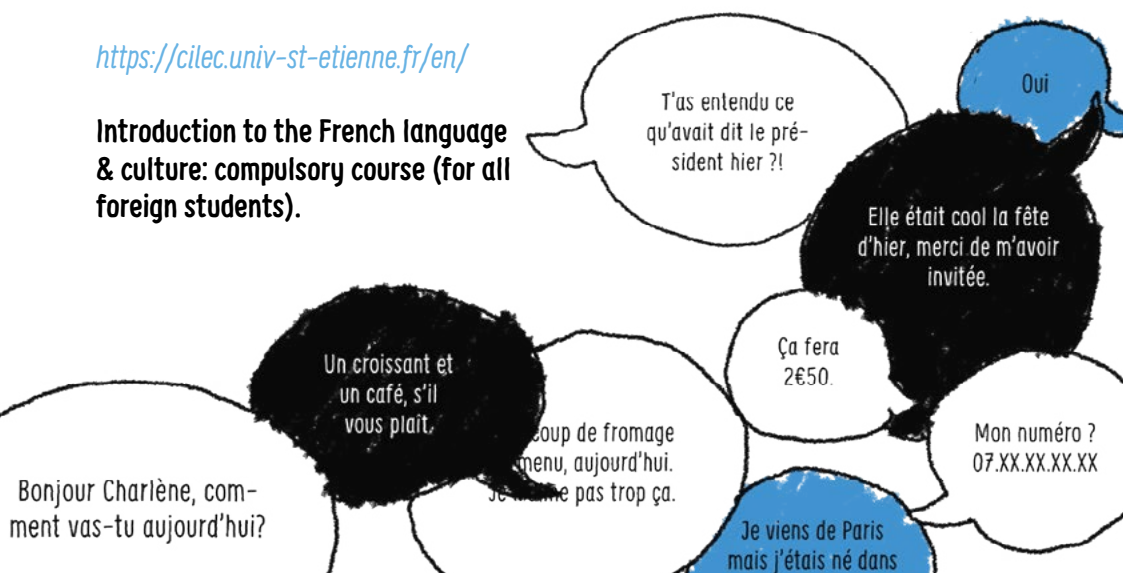

accommodation



In Saint-Etienne there is a variety of accommodation options you can choose from. The incoming students office can help international students to find accommodation in the CROUS residences, private residences or with a host family.

On request by email, a list of accommodations can be provided.

More information: <https://www.univ-st-etienne.fr/fr/international-1/etudiant-international/vie-pratique/logement.html>

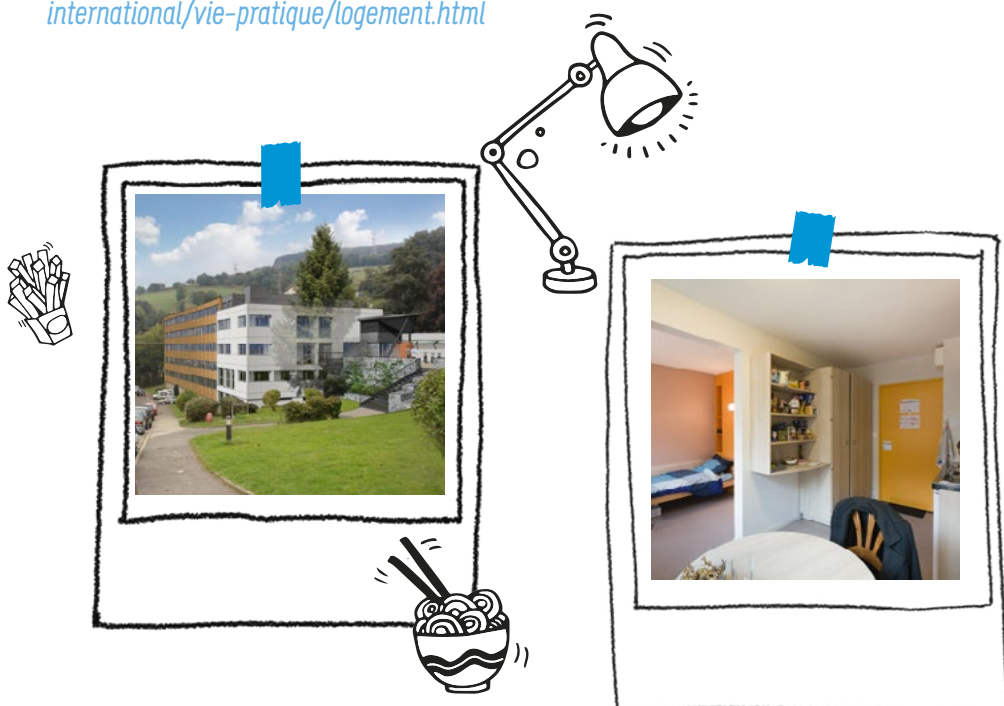

27

facilities 28

Within walking distance of the La Métare Science campus and its facilities (library, restaurant, cafeteria, shops), the Institute of Technology also has its own



settling into campus life



University is also a place for sharing cultures, exchanging and engaging with others. If you are looking for an enriching experience and want to be involved in a project such as culture and sports, the Jean Monnet University offers a large number of activities.

The University is home to many associations: <https://www.univ-st-etienne.fr/fr/vie-etudiante-2/associations.html>

Available sports: <https://www.univ-st-etienne.fr/fr/suaps/planning-des-activites.html>

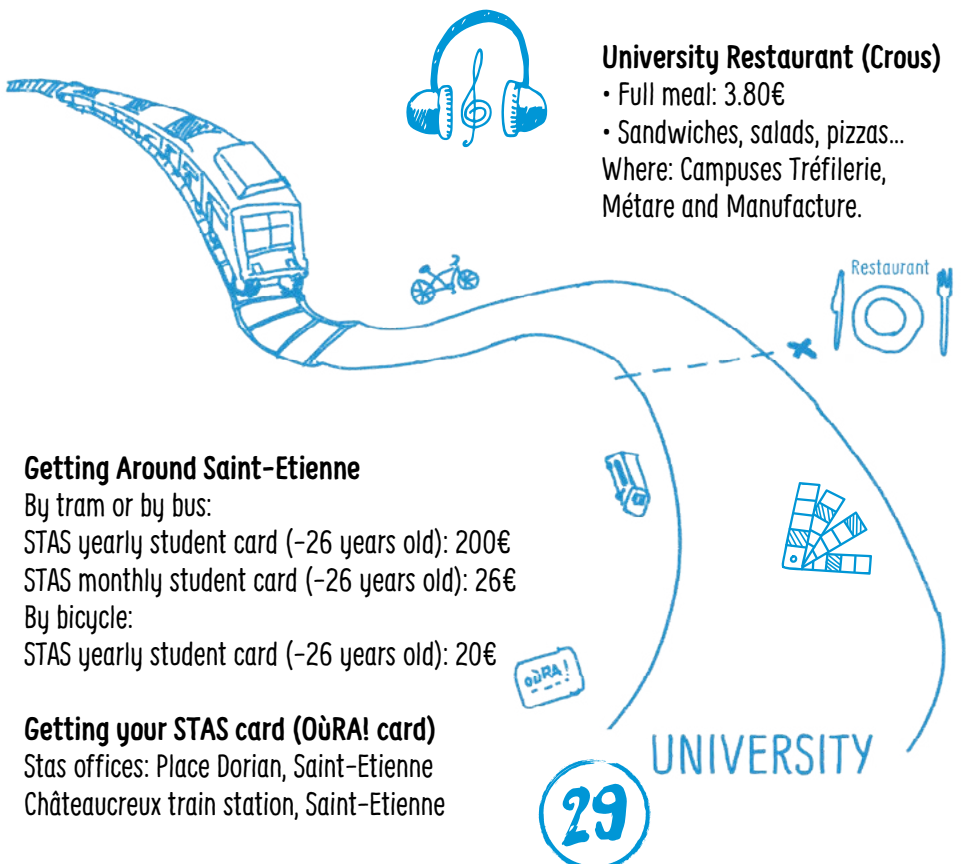

University Restaurant (Crous)

- Full meal: 3.80€
 - Sandwiches, salads, pizzas...
- Where: Campuses Tréfilerie, Métare and Manufacture.

Getting Around Saint-Etienne

By tram or by bus:

STAS yearly student card (-26 years old): 200€

STAS monthly student card (-26 years old): 26€

By bicycle:

STAS yearly student card (-26 years old): 20€

Getting your STAS card (OÙRA! card)

Stas offices: Place Dorian, Saint-Etienne
Châteaucreux train station, Saint-Etienne

5 conditions

- 1- A formal entrance qualification: the Baccalauréat or a University entrance examination
- 2- Assessment of academic results over the previous two years taken into account.
- 3- Selection process
- 4- Level B2 in French or English
- 5- Introduction to the French language & culture: compulsory course (for all foreign students)

ERASMUS STUDENTS

The Socrates/Erasmus programme assists staff and student mobility between European countries within the European Union.

We have bilateral agreements with over 70 colleges or universities.

To **apply** as an Erasmus student, you must:

- be a registered student in one of these universities. **Check with your home university that there is a Bilateral agreement with us.**
- be studying a subject area for which we have an agreement with your college.
- be chosen by your college for an Erasmus/Socrates exchange programme.
- Apply as soon as possible as an Erasmus student through the international officer of your present university who will inform us about your application.
- **Deadlines** for submitting applications:
- 1st semester and full year: 25th May/ 2nd semester: 25th October

EU STUDENTS (NON-ERASMUS) OR NON EU STUDENTS

In addition to our Erasmus exchange students we also welcome other EU students to study at the IUT for a semester, an academic year or longer.

- Students can choose from the same range of full-time courses as French students and are taught and examined by the same method. After the exam board meetings students are posted a transcript of results on the course they attended, which are convertible to ECTS credits.
- Students pay a registration fee after they have been accepted onto a course at the IUT.
- Apply with "Campus France": <https://www.campusfrance.org/fr>

EUROPEAN NATIONALS (EU)

- 1 copy of official invitation letter or certificate of admission
- student card
- learning agreement
- diplomas
- birth certificate
- 3 passport photos
- passport or identity card
- european health card
- vaccination certificate

NON EUROPEAN NATIONALS (NON EU)

- 1 copy of official invitation letter or certificate of admission
- student card
- learning agreement
- diplomas
- birth certificate
- 3 passport photos
- passport or identity card
- visa
- vaccination certificate

contacts

www.iut.univ-st-etienne.fr

7 international coordinators
A wonderful and active team!!!

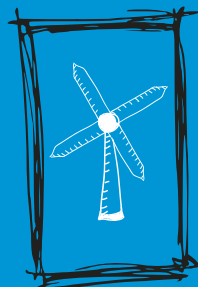

Address

International Relations Office
IUT de Saint-Étienne
28 avenue Léon Jouhaux
42023 SAINT-ETIENNE cedex 2
FRANCE

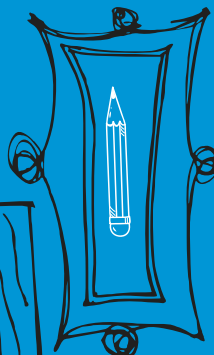

International Office

Tel: +33 (0)4 77 46 33 15
Fax: +33 (0)4 77 46 33 05
iutri@univ-st-etienne.fr

